

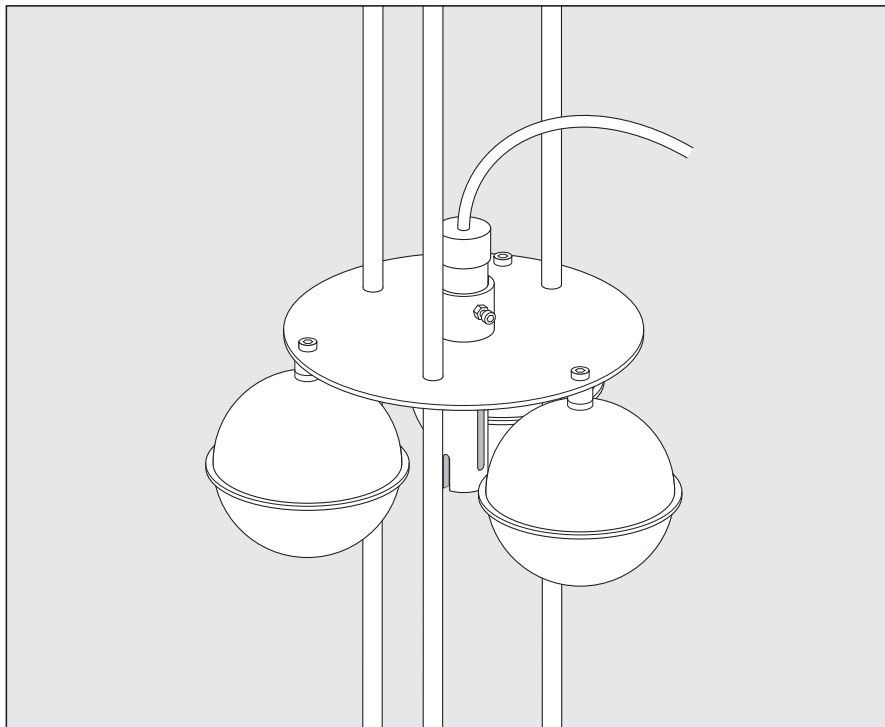

RAYCHEM
TraceTek

Fast Fuel Sensor and Float Assembly

Installation Manual



FAST FUEL SENSOR AND FLOAT ASSEMBLY WARNINGS & NOTIFICATIONS

Throughout the guide the following symbols identify:



IMPORTANT: Recommendations that should be followed.



WARNING: Particularly important safety warnings that must be followed.



IMPORTANT:

Be sure to make the electrical connections to the monitoring and alarm system in a clean, dry area.



WARNING: BURN HAZARD

Do not get hot adhesive on your bare skin. The hot adhesive will burn your skin.



WARNING: FIRE HAZARD

Heat guns and flameless heating tools can cause fire or explosions in hazardous areas. Be sure there are no flammable materials or vapors in the area before using these tools. Follow all site safety guidelines when working in hazardous areas.

Component approvals and performance are based on the use of specified parts only.



WARNING: HEALTH HAZARD

Overheating heat-shrinkable tubes or Solder Sleeves will produce fumes that may cause irritation. Use adequate ventilation and avoid charring or burning. Consult MSDS RAY3122 for further information.

CHEMTREC 24-hour emergency telephone: (800) 424-9300

Non-emergency health and safety information: (800) 545-6258



WARNING: The FFS can be damaged if immersed in water and the water freezes. The sensor must be removed from the water prior to freezing (i.e. by draining the area or moving the sensor) or heating measures must be taken to prevent the water from freezing.



WARNING: Failure to regularly test or clean the FFS could prevent it from functioning properly and impede or preclude alarm occurrence. Under normal application conditions, test and clean the FFS at least once every 6 months, per the instructions in Section 6 Care and Maintenance. More frequent testing and cleaning may be needed depending on application conditions, particularly if the device is contaminated or covered with foreign materials, e.g. biofilm, fungus, mildew, algae, mud, etc. which could delay or prevent contact of leaked hydrocarbon fuel with the sensor blade coating. Sufficient hydrocarbon fuel must physically contact the sensor blade coating in order for an alarm to occur. Replacement may be necessary if cleaning does not restore the FFS probe.

CONTENTS

I. GENERAL INFORMATION	1
1.1 Use of the Manual.....	1
1.2 General Description	1
1.3 Safety Guidelines.....	1
2. FFS AND FLOAT ASSEMBLY PARTS.....	2
2.1 Float Assembly Type	2
2.2 Float Assembly with Guide	3
3. INSTALLATION AND ASSEMBLY INSTRUCTIONS	4
3.1 Installing the Support Rods to the Bottom Plate	4
3.2 Installing the Float Assembly onto the Support Rods.....	5
3.3 Installing the 2 M Extension Rods	6
3.4 Installing the Top Plate.....	7
3.5 Mounting the Float Assembly.....	8
3.6 FFS Wiring.....	9
3.7 Install the FFS in the Float Assembly.....	11

1. GENERAL INFORMATION

1.1 USE OF THE MANUAL

This manual covers the procedure for installing the nVent RAYCHEM TraceTek Fast Fuel Sensor (FFS) into a Float Assembly (Part Numbers: 1244-004251, TT-FFS-FLOAT-1M and 1244-004252, TT-FFS-FLOAT-2M). Be sure to carefully read this document in order to become thoroughly acquainted with its contents prior to installation.

It is recommended that only the water resistant version (TT-FFS-WR) of the FFS be used in Float Assembly applications. These versions are specifically designed to withstand exposure to water. The recommended part numbers are as follows:

Part Number	Catalog Number
P000002304	TT-FFS-WR-100-L-10
P000002305	TT-FFS-WR-100-MC-10
P000002306	TT-FFS-WR-100-MC-3
P000002289	TT-FFS-WR-250-L-10
P000002290	TT-FFS-WR-250-MC-10
P000002303	TT-FFS-WR-250-MC-3

Follow the instructions included with the project specific engineering documents and drawings. For the warranty and agency approvals to apply, you must follow the instructions in this manual and all project-specific engineering drawings and documents. In the event that there is a conflict between details and procedures shown on the project-specific engineering drawings and documents and the details and procedures shown in this document, contact your local TraceTek representative for clarification.

1.2 GENERAL DESCRIPTION

The FFS is a hydrocarbon leak detector capable of detecting hydrocarbons that have collected in drainage pits or sumps or are floating on water.

Mounted in a Float Assembly, the FFS provides an alarm in the event that hydrocarbons have leaked into a water source or location. This alarm is provided whether a sheen of fuel is present on the water's surface or collecting at the bottom of a containment pit when no water is present.

When connected to an nVent RAYCHEM TraceTek Sensor Interface Module or Alarm Panel, this assembly provides full time monitoring and helps prevent accidental fuel discharge into water drainage systems. This minimizes environmental contamination and the business consequences which often accompany such releases.

1.3 SAFETY GUIDELINES

The safety and reliability of any leak detection systems depends on both the quality of the products selected and the manner in which they are designed, installed, and maintained. Incorrect handling, installation, or maintenance of any of the system components can cause the system to fail. The information, warnings, and instructions contained in this guide are important. Read and follow them carefully to minimize this risk and to ensure that the system performs reliably.

Throughout the guide the following symbols identify:



IMPORTANT: Recommendations that should be followed.



WARNING: Particularly important safety warnings that must be followed.

2. FFS AND FLOAT ASSEMBLY PARTS

2.1 FLOAT ASSEMBLY TYPE

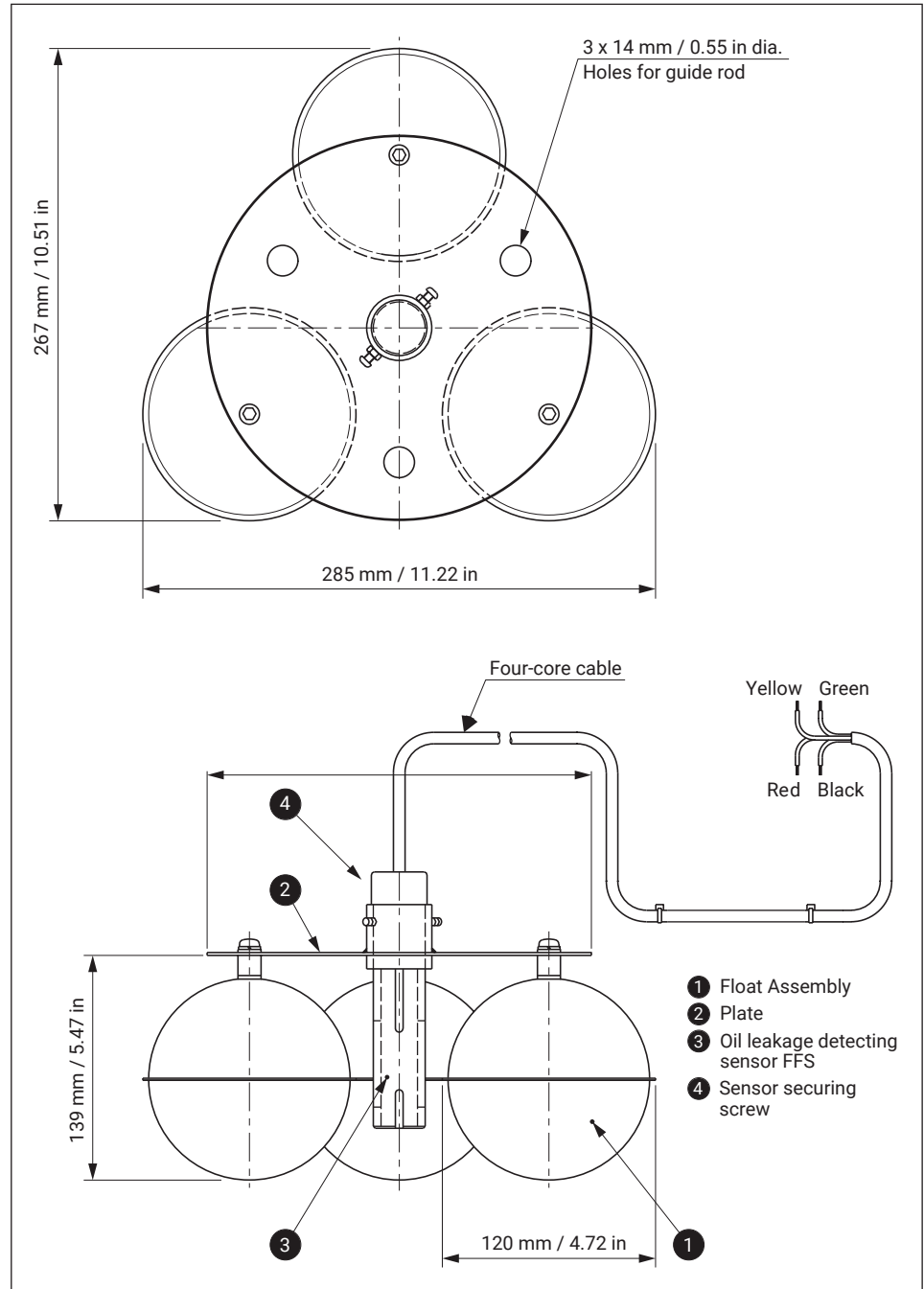

2.2 FLOAT ASSEMBLY WITH GUIDE

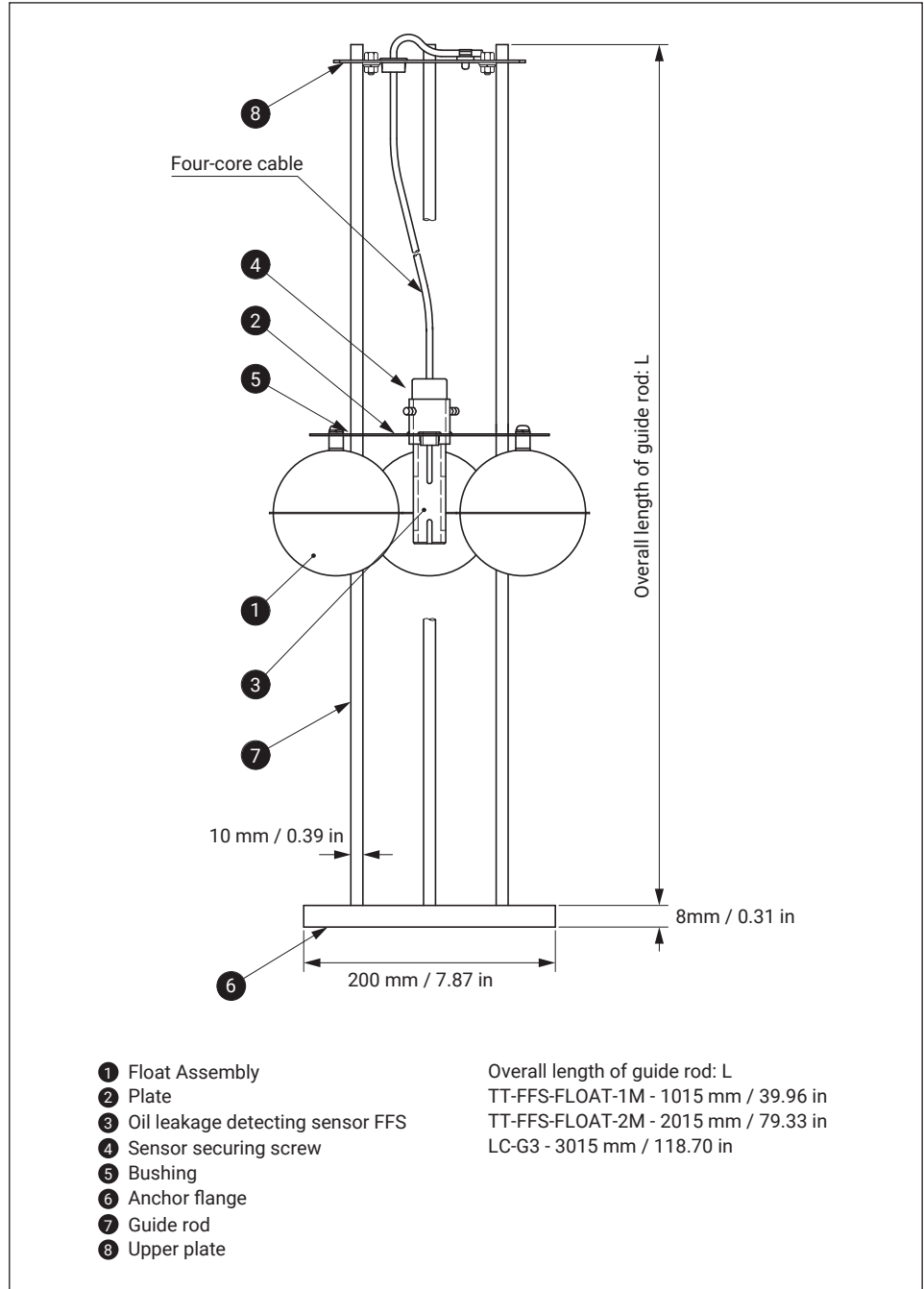

3. INSTALLATION AND ASSEMBLY INSTRUCTIONS

Remove all of the Float Assembly components from their packaging and assemble them as follows:

3.1 INSTALLING THE SUPPORT RODS TO THE BOTTOM PLATE

Place the threaded bottom plate on the ground and screw the three support rods into the bottom plate.

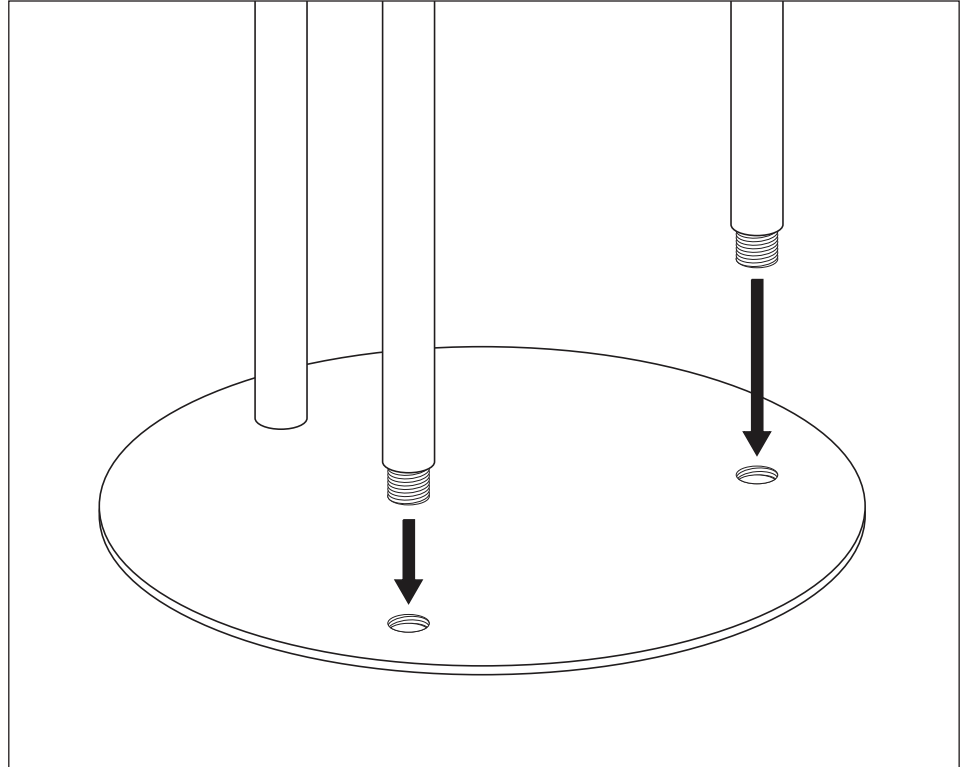

3.2 INSTALLING THE FLOAT ASSEMBLY ONTO THE SUPPORT RODS

Position the Float Assembly with mounting plate over the rods. Insert the support rods into the Float Assembly guide holes and lower it down to the bottom plate.

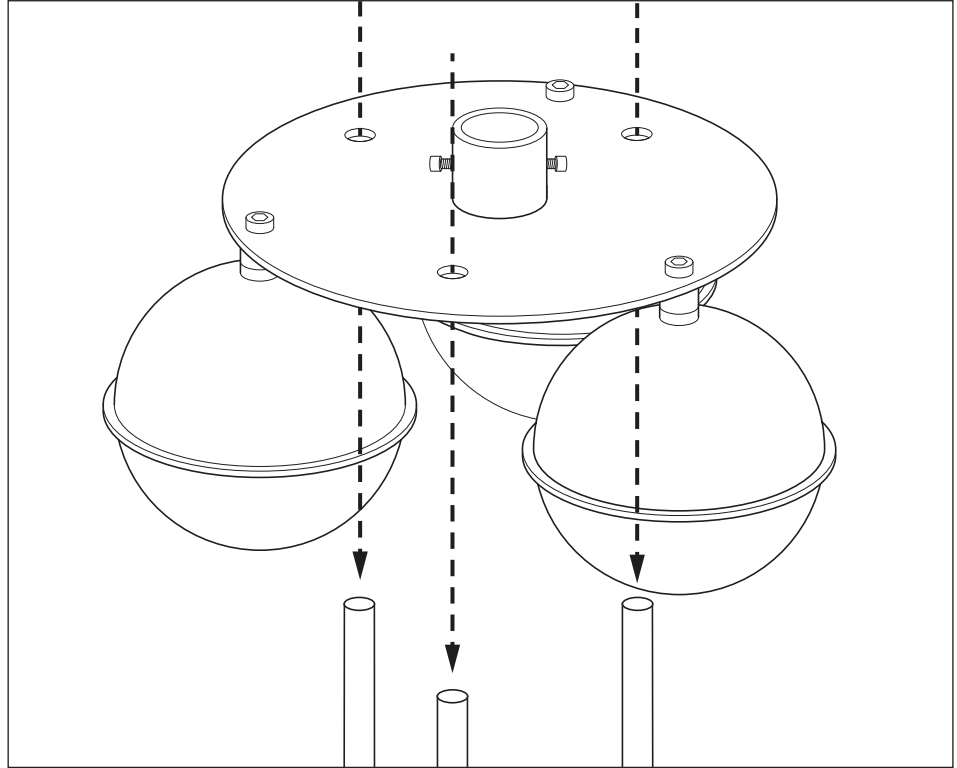

3.3 INSTALLING THE 2 M EXTENSION RODS

Screw the upper rods to the lower tubes (for 2 meter versions).

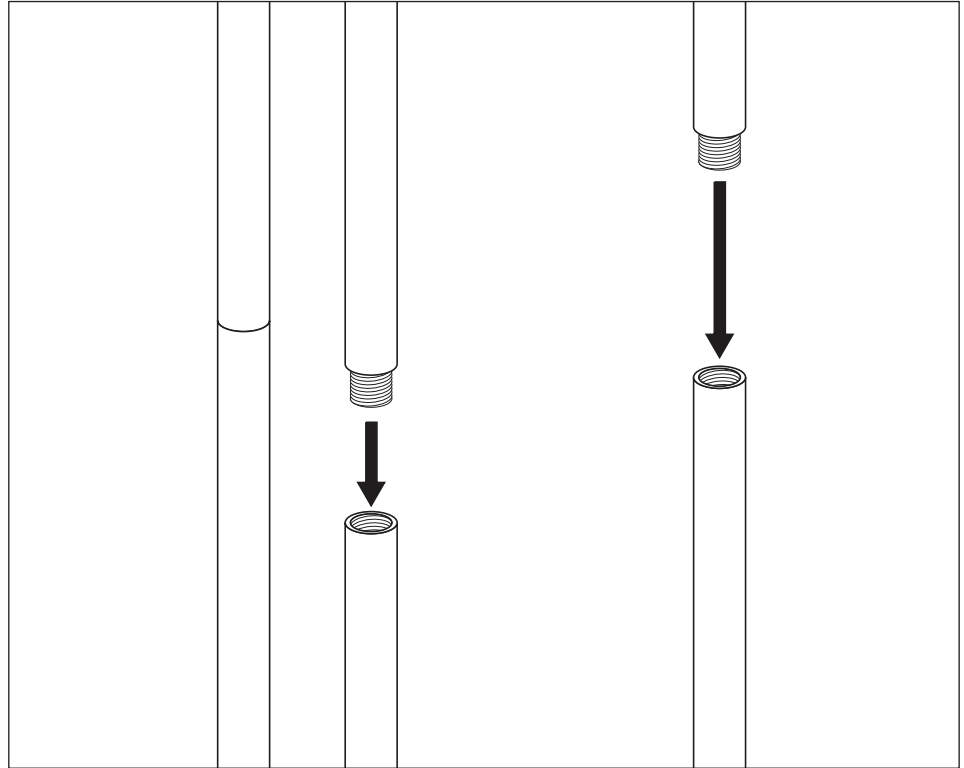

3.4 INSTALLING THE TOP PLATE

Place the top plate on the rods and secure it with the three screws.

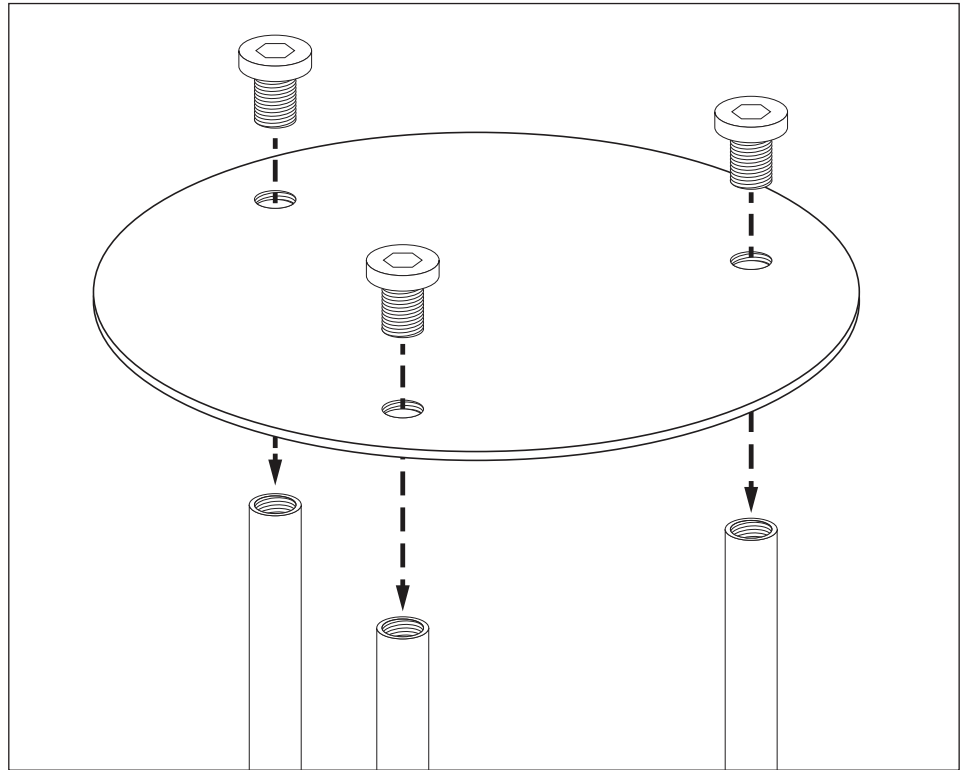

3.5 MOUNTING THE FLOAT ASSEMBLY

The Float Assembly should now be secured in the area to be monitored. This must be done in such a way that the free movement of the Float Assembly is not restricted by the mounting hardware.

Connection to the Float Assembly is recommended only at the top and bottom plates. Support brackets (not supplied) can be bolted to the Float Assembly at these points as shown below. The brackets can be secured directly to a wall or support structure or bolted to a piece of channel.

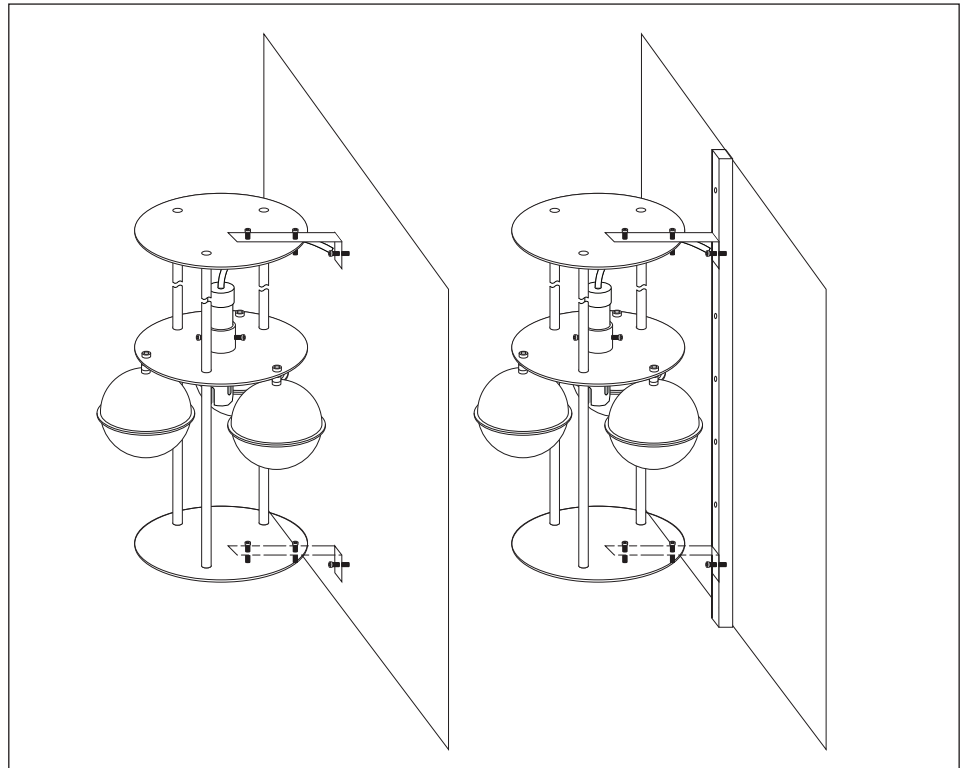

3.6 FFS WIRING

The FFS should be wired back to the nVent RAYCHEM TraceTek monitoring and alarm system prior to insertion into the Float Assembly. This is especially true if the Float Assembly is already in water since there is risk of getting water into the FFS connectors or wiring.



IMPORTANT:

Be sure to make the electrical connections to the monitoring and alarm system in a clean, dry area.

If the FFS has a metal connector, it may simply be inserted into the nVent RAYCHEM TraceTek Jumper Cable connector. Tighten the connector threads securely and be sure to seal the connectors with the supplied environmental heat shrink seal. This is an important step to ensure water does not penetrate the connector, causing corrosion and resulting in unit failure. The environmental heat shrink seal should be installed as follows:

APPLY ENVIRONMENTAL SEAL

- Before making the connector assemblies, slide the heat shrink seal onto one of the cables. Connect the pin and socket connectors together firmly. Center the heat shrink seal over the pin/socket connection. Heat shrink the seal over the connection, beginning in the center and shrinking towards the ends until the seal fully conforms to the shape of the connection and adhesive flows from each end of the seal.



WARNING: BURN HAZARD

Do not get hot adhesive on your bare skin. The hot adhesive will burn your skin.



WARNING: FIRE HAZARD

Heat guns and flameless heating tools can cause fire or explosions in hazardous areas. Be sure there are no flammable materials or vapors in the area before using these tools. Follow all site safety guidelines when working in hazardous areas.

Component approvals and performance are based on the use of specified parts only.



WARNING: HEALTH HAZARD

Overheating heat-shrinkable tubes or Solder Sleeves will produce fumes that may cause irritation. Use adequate ventilation and avoid charring or burning. Consult MSDS RAY3122 for further information.

CHEMTREC 24-hour emergency telephone: (800) 424-9300

Non-emergency health and safety information: (800) 545-6258

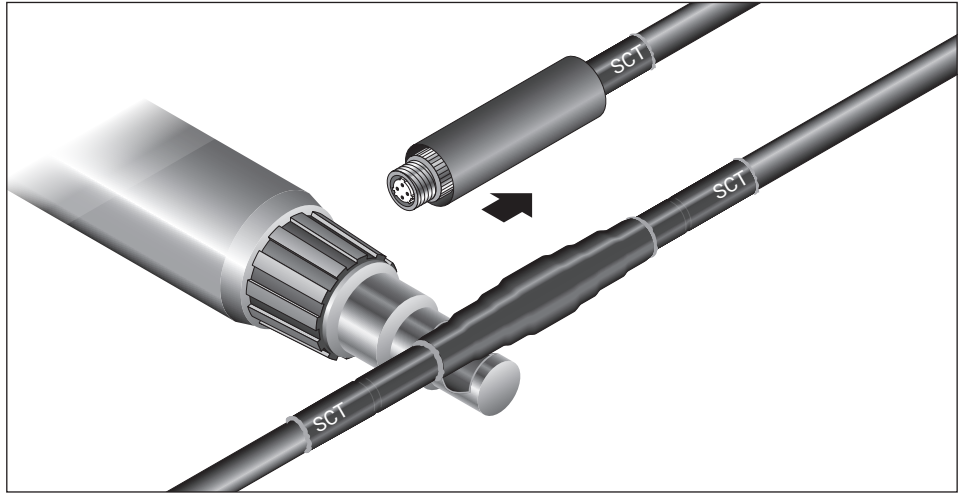

- Avoid overheating the heat shrink seal. The heat shrink seal should not smoke or tear as part of the installation process. If this happens, wait for the area to cool, remove the overheated seal and apply a new one.
- Let the entire connector area cool before handling the cable.



IMPORTANT:

Do not leave connector open to environment. If the connector becomes wet or contaminated, it will need to be replaced.

If the FFS has individual wires at the end of its cable, these wires must be terminated in such a way that water will not get to the electrical connections. An IP66 rated enclosure is recommended. Be sure to observe the color coding on the wires per the image below.

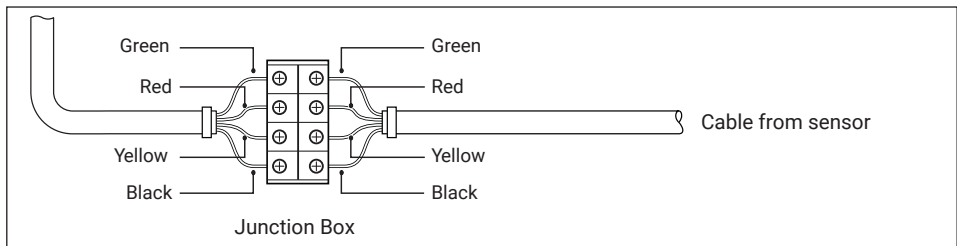

IMPORTANT:

The FFS is approved for use in hazardous areas. However, the electronic monitoring and alarm systems may not be approved. Be sure to confirm these area ratings of the electronics and employ the necessary barrier protection components and equipment mounting locations as required.

3.7 INSTALL THE FFS IN THE FLOAT ASSEMBLY

Install the FFS into the Float Assembly using the set screw in the center support section. Adjust the height of the FFS so that the water level will be about half way up one set of the slots in the housing. Initial positioning can be estimated by using the center seam of the Float Assembly spheres as the water level. Actual water level alignment with the sensor housing slots must be confirmed after final installation in the monitoring area.



IMPORTANT:

Ensure the sensor securing screws do not make contact with the TT-FFS blade within the orange tube as this will cause failure of the sensor.

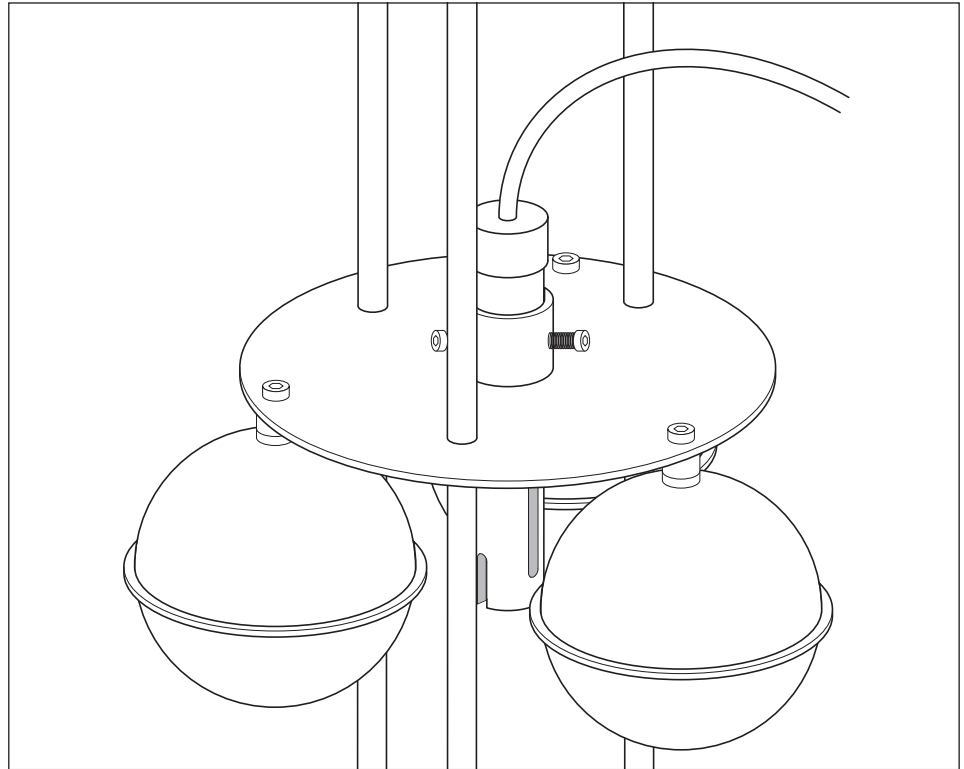

North America

Tel +1.800.545.6258
Fax +1.800.527.5703
thermal.info@nvent.com

Europe, Middle East, Africa

Tel +32.16.213.511
Fax +32.16.213.604
thermal.info@nvent.com

Asia Pacific

Tel +86.21.2412.1688
Fax +86.21.5426.3167
cn.thermal.info@nvent.com

Latin America

Tel +1.713.868.4800
Fax +1.713.868.2333
thermal.info@nvent.com



nVent.com

© 2019 nVent. All nVent marks and logos are owned or licensed by nVent Services GmbH or its affiliates. All other trademarks are the property of their respective owners. nVent reserves the right to change specifications without notice.